

CHAPTER 14

1

# Tiling an Area

**Goal** Tile an area using software.

- How many congruent shapes will tile this area?  
Use Geometer's Sketchpad or the grid below.

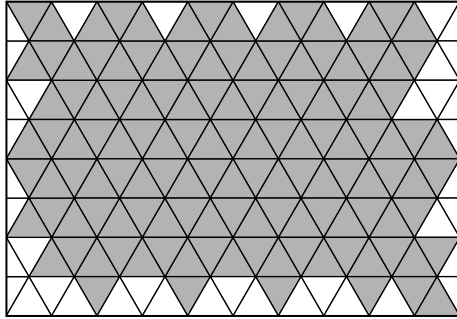

32 congruent shapes

- Tile the area below with this shape .

Cover as much of the area as possible. Use reflections only and show the lines of reflection on the grid.

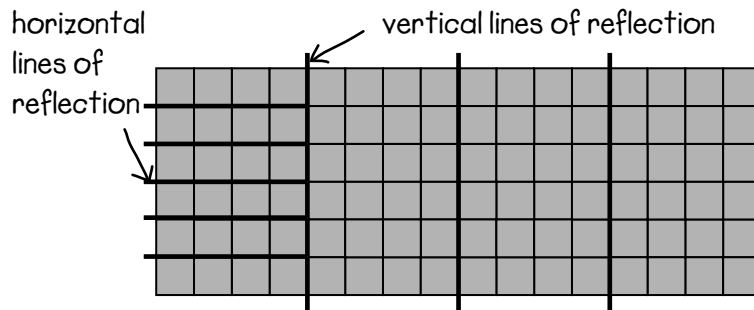

- How would you move this shape  to tile the lightly shaded area below?

Circle the correct answer.

- translate 4 squares left
- rotate 90° clockwise
- translate 2 squares right and 1 square down
- reflect about the horizontal

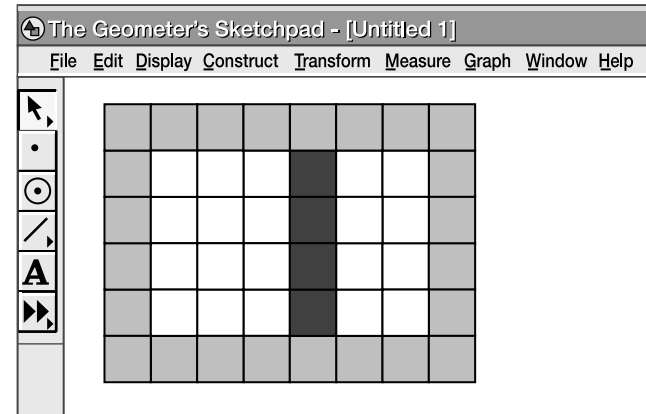

## At-Home Help

**Congruent** means the same shape and size.

To tile an area, use repeated congruent shapes. There should be no gaps and no overlaps.

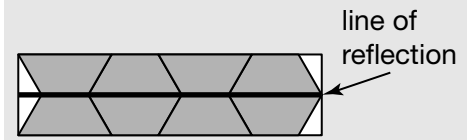

A **line of reflection** is a line in which a shape is reflected. Both shapes are identical in size and shape, but one appears flipped.

For example, in the picture above, there is a horizontal line of reflection.

## Describing Tiling Patterns

**Goal**

Describe tiling patterns.

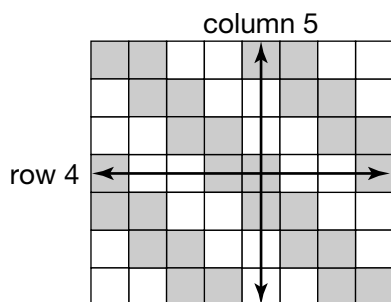

1. Which columns have different pattern rules?  
How do you know?

Columns 1, 2, 3, and 4 have different pattern rules  
because either they start with tiles of a different  
colour or they start with different numbers of tiles of  
a particular colour. Columns 5, 6, 7, and 8 are identical  
to columns 1, 2, 3, and 4 respectively.

2. Write a pattern rule for columns 5 and 7. How are the pattern rules the same?  
How are they different?

(column 5) Start with 1 shaded tile, then 2 white, 2 shaded, and 2 white tiles. (column 7) Start  
with 1 white tile, then 2 shaded, 2 white, and 2 shaded tiles. Pattern rules are the same in that  
the tile colour changes based on the same sequence: 1 tile of one colour, 2 tiles of other colour,  
and so on. Pattern rules are different in that the colours of the tiles in the two columns are  
reversed (what is white in one column is shaded in the other).

3. Record the number of white and shaded tiles in each column. Use the table below.

| Column | White tiles | Shaded tiles |
|--------|-------------|--------------|
| 1      | 4           | 3            |
| 2      | 3           | 4            |
| 3      | 3           | 4            |
| 4      | 4           | 3            |
| 5      | 4           | 3            |
| 6      | 3           | 4            |
| 7      | 3           | 4            |
| 8      | 4           | 3            |

**At-Home Help**

A **tiling pattern** is a pattern of repeated congruent shapes that fit together with no gaps and no overlaps.

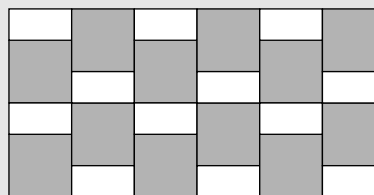

A **pattern rule** describes how you can reproduce a pattern.

For example, the pattern rule for the first column in the picture above is:

Start with 1 white rectangle, then 1 shaded square, 1 white rectangle, and 1 shaded square.

# Extending Tiling Patterns

**Goal** Write a pattern rule to extend a pattern.

1. Which pattern rule best describes the first row of this tiling pattern? Circle the correct answer.

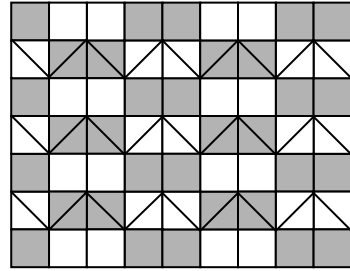

Start with 1 shaded tile, then alternate 1 white tile and 1 shaded tile.

Start with 1 white tile, then alternate 2 shaded tiles and 2 white tiles 4 times.

Start with 1 shaded tile, then alternate 2 white tiles and 2 shaded tiles 2 times.

Start with 1 white tile, then alternate 2 shaded tiles and 2 white tiles.

2. Look at the tiling pattern in Question 1. Write a pattern rule for any column.

Suggested answer: (column 1) Start with 1 shaded tile, then alternate 1 white tile  
(with a diagonal through top left and bottom right vertices) and 1 shaded tile 3 times.

3. Write a pattern rule for a row on this rug based on the letter F.

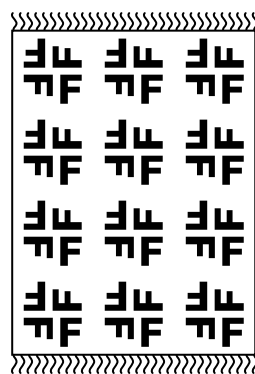

Suggested answer: Start with a backward and upside down F.  
Hold bottom right corner of F down and turn 90° clockwise. Repeat  
the same turn 2 more times. Repeat this sequence 2 more times.

## At-Home Help

A **pattern rule** states the starting point of a pattern, a description of the attributes that change, and the number of repetitions.

For example, the pattern rule for the first row is start with 1 shaded tile, then alternate 2 white tiles and 3 shaded tiles 3 times, and end with 2 white tiles.

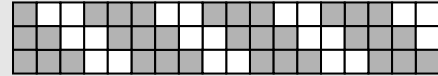

# Translating Shapes on Grids

**Goal**

Identify the rule for translating a shape.

- Which statement best describes this translation?  
Circle the correct answer.

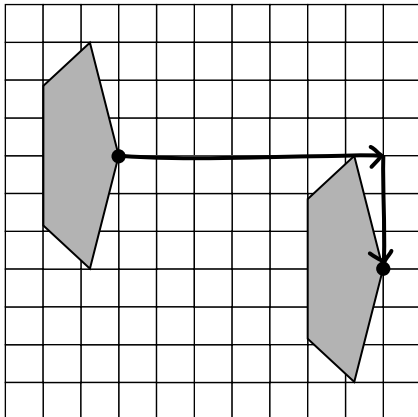

- right 6 squares, down 3 squares
- left 7 squares, up 4 squares
- right 7 squares, down 3 squares**
- right 6 squares, down 2 squares

- Greg wrote rules to describe the translation of a shape. Follow Greg's steps in the box.  
Show the result of each translation on the grid.

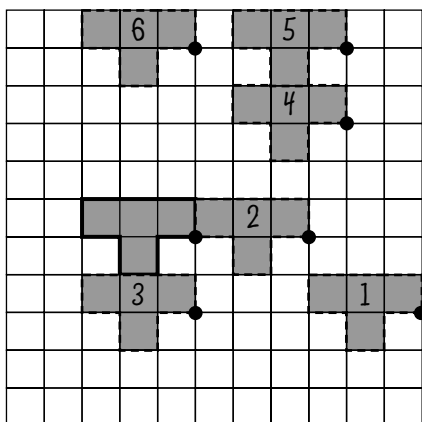

**At-Home Help**

A **translation** is a movement in a straight line. It can be left, right, up, or down.

For example, the translation shown is left 3 squares and down 5 squares.

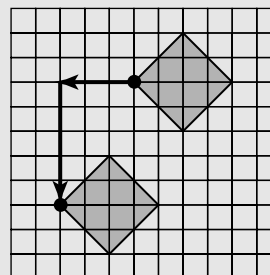

Start with a T-shape.

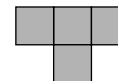

- Step 1: right 6, down 2
- Step 2: left 3, up 2
- Step 3: left 3, down 2
- Step 4: right 4, up 5
- Step 5: up 2
- Step 6: left 4

# Rotating Shapes

**Goal** Rotate shapes in a pattern.

You will need a protractor and a ruler.

- Which rotation rule was used? Circle the correct answer.

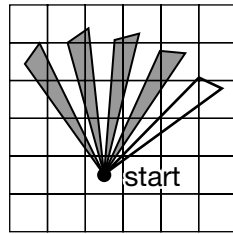

- Rotate 20° counterclockwise 4 times.
- Rotate 25° counterclockwise 4 times.
- Rotate 20° counterclockwise 5 times.
- Rotate 25° counterclockwise 5 times.

- Chandra's Rotation Rule**

Choose a vertex on the shape to be the centre of rotation. Rotate 25° counterclockwise 10 times.

Draw the logo using the rotation rule. Label the centre of rotation. Label the angle of rotation showing the direction.

- A shape was rotated to create this logo.

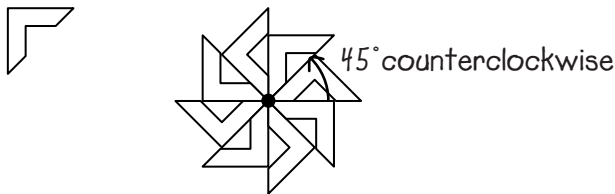

- Identify the centre of rotation. Label it on the logo.
- What is the angle of rotation? Label it on the logo. 45°
- What is a possible direction of each rotation? Label it on the logo.  
counterclockwise (or clockwise)

## At-Home Help

A **rotation** in 2-D is a turn about a point called the **centre of rotation**. When describing a rotation, remember to include both the angle and direction.

For example, this shape was rotated 90° counterclockwise.

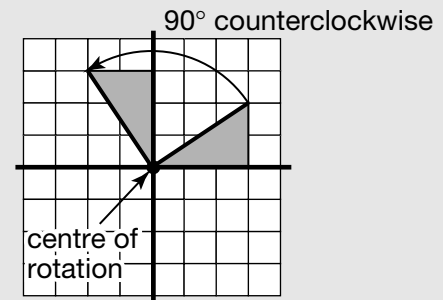

Suggested answer:

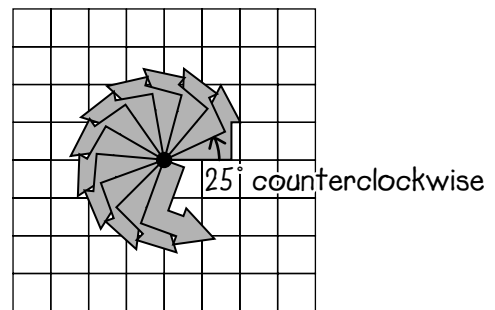

# Communicate About Transformations

**Goal** Describe transformations using math language.

You will need a protractor and a ruler.

1. Name the transformation used to create shapes A, B, and C from the black shape.

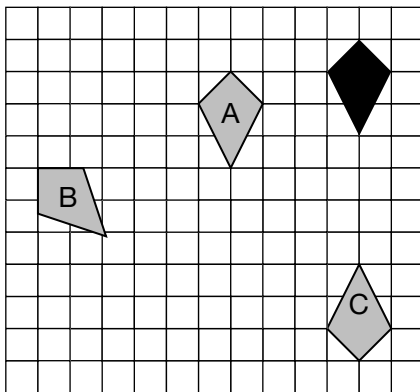

- a) shape A translation, left 4 squares and down 1 square
- b) shape B rotation, 45° counterclockwise
- c) shape C reflection, in line 2 squares below lower side

2. Look at the picture in Question 1. What kind of transformation is each student describing? Identify the shape by its letter. Explain how you know.

- a) Isabelle: My transformation changed the orientation of the shape.

shape B or shape C

Rotations and reflections change the orientation of a shape.

- b) Zev: My transformation changed the position of every point on the shape.

shape A, shape B, or shape C

Translations change the position of every point on a shape but the orientation remains the same.

Rotations and reflections change the position of every point on a shape and change the orientation.

3. a) Copy the diagram on grid paper.  
Reflect it in the darker line.

- b) Describe the effect of the reflection.

Reflections are mirror images of the original shape. Both shapes are congruent, but the orientation of the reflection is different from the original.

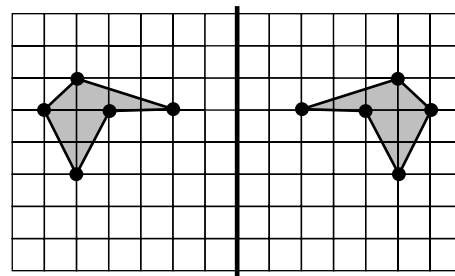

## At-Home Help

**Transformations** can change the position, orientation, and size of a shape.

Translations change the position of a shape but not its orientation.

Rotations and reflections change both the position and orientation of a shape.

When describing transformations, remember to use the Communication Checklist.

### Communication Checklist

- Did you use math language?
- Did you include diagrams?
- Did you show the right amount of detail?

# Modelling Congruence with Transformations

**Goal** Show congruence using transformations.

You will need a protractor and a ruler.

1. Circle the congruent shapes. Explain how you know. Use transformation language.

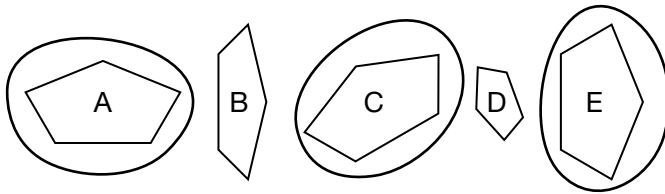

A, C, and E are identical in shape and size, but not in orientation. C and E are rotations of A.

2.

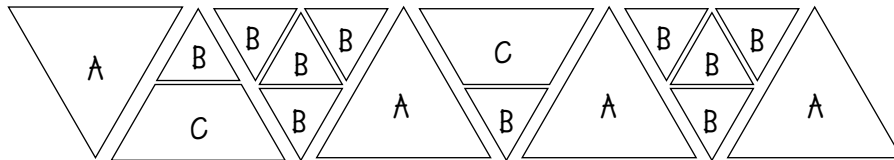

- a) Identify all sets of congruent shapes. Use the letters A, B, and C to show shapes that are congruent.
- b) Describe the shape in each set.
- (set A) large equilateral triangles
- (set B) small equilateral triangles
- (set C) trapezoids
- c) Choose one set of congruent shapes. Describe the transformations you used to show congruence.
- (set A) rotation of  $180^\circ$  clockwise (or reflection in a horizontal line); translations to the right
- (set B) rotations of  $180^\circ$  clockwise (or reflections in a horizontal or vertical line); translations to the right and down
- (set C) rotation of  $180^\circ$  clockwise (or reflection in a horizontal line); translation to the right

## At-Home Help

**Congruent** means the same shape and size. Congruent shapes may be translated, rotated, or reflected.

For example, all three triangles are congruent.

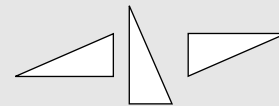

## Exploring Similarity

**Goal** Identify similar figures using transformations.

You will need a ruler.

- Two shapes were made using elastics. Why are these shapes similar?

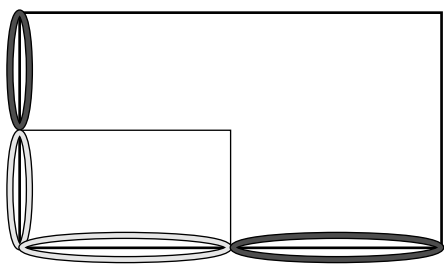

The larger rectangle is twice as big as the smaller rectangle.

- Yvette began to enlarge this triangle using elastics.

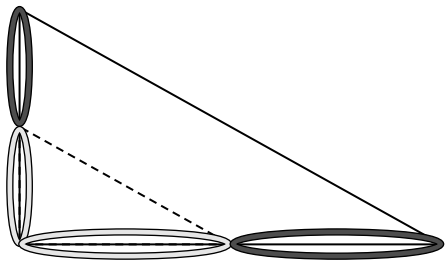

Draw the enlarged similar triangle.

- What does a smaller similar triangle look like? Draw it.

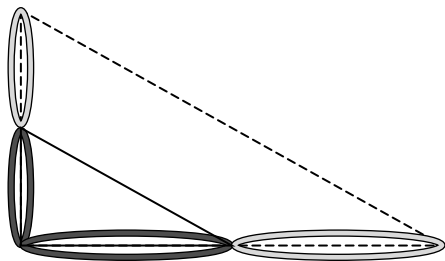

### At-Home Help

**Similar** means the same shape but a different size.

For example, both trapezoids are similar.

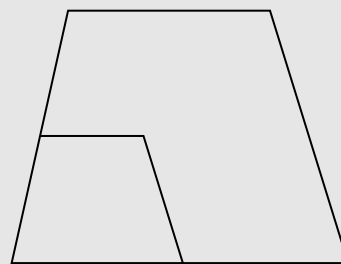



# Test Yourself

Circle the correct answer.

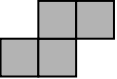
1. How would you move this shape  to tile the lightly shaded area below?

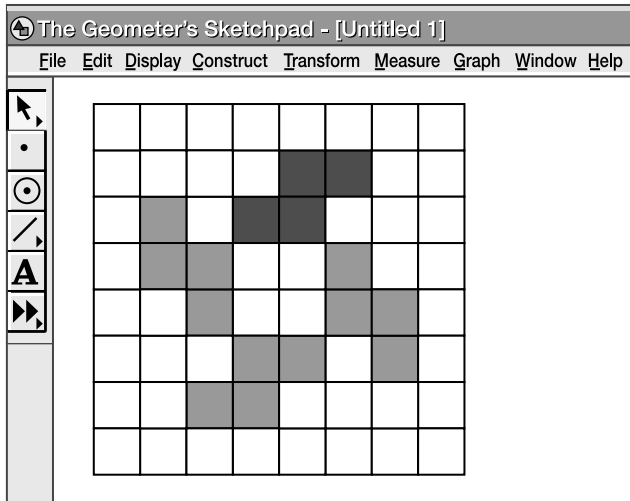

- A. translate down 3 squares and left 2 squares
  - B. rotate 90° clockwise**
  - C. translate right 2 squares and down 3 squares
  - D. reflect in a horizontal line
2. Which rows have a different pattern rule?

- A. rows 1 and 5
- B. rows 2 and 6
- C. rows 3 and 7
- D. rows 4 and 5**

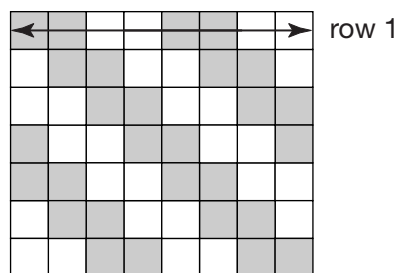

# Test Yourself Page 2

3. Which statement best describes the translation shown?

- A. translate right 6 squares and down 4 squares
- B. translate right 5 squares and down 4 squares
- C. translate left 5 squares and up 4 squares
- D. translate left 4 squares and up 5 squares**

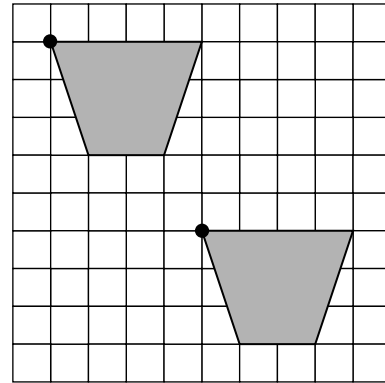

4. Which rotation rule was used to create the logo?

- A. Rotate  $30^\circ$  counterclockwise about B 5 times.
- B. Rotate  $45^\circ$  counterclockwise about O 7 times.**
- C. Rotate  $45^\circ$  counterclockwise about A 5 times.
- D. Rotate  $30^\circ$  counterclockwise about O 7 times.

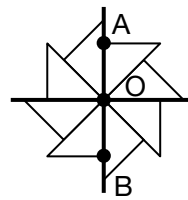

5. Which shapes are congruent and how do you know?

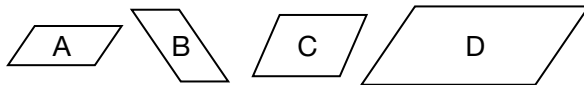

- A. Translate A to C and A covers C exactly.
- B. Rotate A to B and A covers B exactly.**
- C. Reflect A to D and A covers D exactly.
- D. Translate A to B and A covers B exactly.

6. Look at the picture in Question 5. Which shapes are similar and how do you know?

- A. C is twice as large as B.
- B. C is twice as tall as A.
- C. D is twice as large as A.**
- D. D is twice as tall as B.